

PFA SERIES MODELS

FULLY AUTOMATIC VENTLESS COUNTERTOP DEEP FRYER

 *Advanced by Design*



- FULLY AUTOMATED COOKING SYSTEM
- FRONT LOADING/ FRONT DISPENSING
- SMALL FOOTPRINT
- PROGRAMMABLE PRESETS
- ODORLESS
- INTEGRAL VENTLESS HOOD
- INTEGRAL FIRE SUPPRESSION OPTION
- LARGEST OUTPUT
- EASY TO CLEAN
- FULLY ENCLOSED
- INTEGRAL INFRARED, CERAMIC HEAT LAMP AND OIL DRAINAGE KIT
- NON-STICK BASKET



Available from

Malibu
CORPORATION LTD.

0161 874 5400 www.malibu-corporation.co.uk

TELEPHONE:
25-4504
5472
www.perfect Fry.com

The Benchmark in Ventless Deep Frying



CLEARANCES

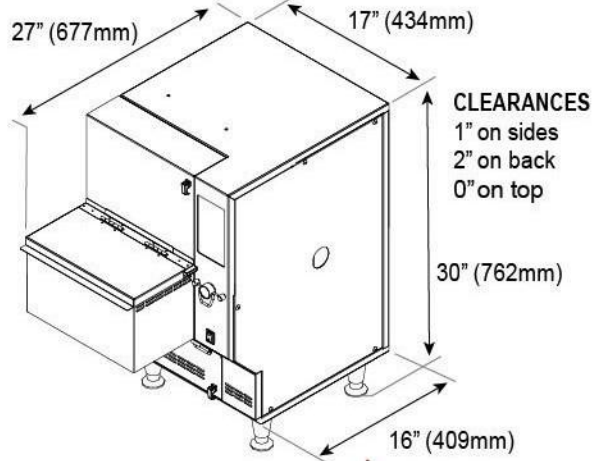

AIRFLOW DIAGRAM

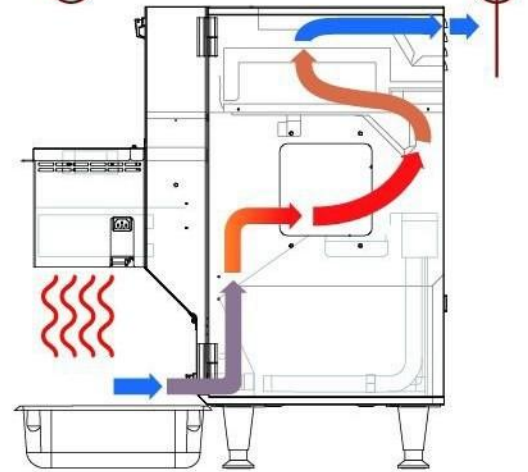

SPECIFICATIONS TABLE

MODEL	DSA7200	DSA5700	DSA3000
POWER SUPPLY (volts)	240	240	240
CURRENT (amps)	32	26	13
CIRCUIT CURRENT (amps)	min 40*	min 30**	min20
CORD OPTION	Field Wired	Field Wired	Power Cord
POWER (kilowatts)	7.6	6.1	3.4
CAPACITY (lbs/hr)‡	90	70	35
HEATER ELEMENT (kilowatts)	7.2	5.7	3.0

Models with optional Integral Fire Suppression System are PFA7200, PFA5700 and PFA3000 Respectively. All other specifications are the same.

GENERAL SPECIFICATIONS

*For use on an individual branch circuit rated 40A minimum. For supply connectors, use minimum no. 8 AWG wire (40A rated). This fryer must be properly connected to a grounded, dedicated 240 VAC single phase circuit according to local installation standards and codes.

**For use on an individual branch circuit rated 30A minimum. For supply connectors, use minimum no. 10 AWG wire (30A rated). This fryer must be properly connected to a grounded, dedicated 240 VAC single phase circuit according to local installation standards and codes.

‡ Based on up to 1minute fast fries

Heat Lamp (see below)	Integral On All Units
Phase	Single (3 wire)
Cycles	50/60 Hz
Weight	125 lbs (57 kg)
Shipping Weight	135 lbs (62 kg)
Shipping Dimensions	Depth 25" (635 mm) Width 22" (559 mm) Height 30" (762 mm)
Shipping Cube	9.52 ft ³ (.271 m ³)
Oil Capacity	2.75 US Gallons (11 L)
Product Capacity	3 lbs per load

ADVANCED ELECTRONIC CAPABILITIES

- Cook Time Sensitivity (CTS)[™]
- Stand-by Mode
- Preset Counters
- Dual Load Cook Cycle
- Food Type Sensitivity (FTS)[™]
- Hold Time Monitor

RAPIDFRY[™] TECHNOLOGY

RapidFry[™] technology allows the operator to pre-load food into the drawer while other food product is frying in the cooking oil. The second load of food will automatically begin cooking once the first cook cycle is completed.

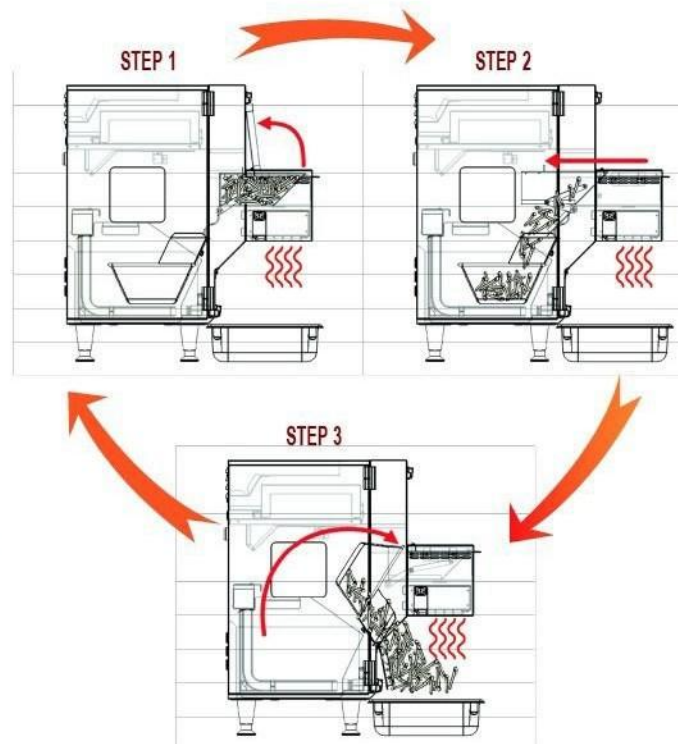

ACCESSORIES

Heat Lamp - 138503
2 amps
240 volt
500 watts
Ordered Separately



SPECIFICATIONS SUBJECT TO CHANGE WITHOUT NOTICE.

© 2011 Perfect Fry Company LLC. PRINTED IN USA.

