



## 24" MIRACLEAN® Gas Griddle

PROJECT \_\_\_\_\_

QUANTITY \_\_\_\_\_

ITEM NO. \_\_\_\_\_

**Standard Features:**

- ▶ 100% customer satisfaction
- ▶ Saves 44% in clean up
- ▶ Cooler kitchen
- ▶ Uniform heat distribution allows you to cook at lower temperatures, reducing shrinkage
- ▶ Saves 32% in energy costs
- ▶ Reduced flavor transfer
- ▶ Zoned temperature control
- ▶ No electrical connections needed

**Options:**

- 4" Legs
- Stand, or Stand with Shelf and Casters
- Cutting Board (Stainless or Richlite)
- Plate Shelf
- Thermostat Knob Guard
- Belly Bar
- Streaked Surface
- Custom Griddle Styles or Configurations
- Security Package



Stand with Casters or 4" Legs are Optional

The Keating MIRACLEAN® Griddle is designed to provide maximum performance with many benefits to the operator. The mirror surface is achieved in a special eight step process. High input burners rated at 30,000 BTU/hr. for natural gas are mounted every 12" to ensure performance and recovery allowing the operator to use zone cooking for different products.

**Saves on energy costs**

Documented energy savings of 32% by Pacific Gas & Electric means dollar savings of up to \$400 per year in energy costs on a 36" model. The MIRACLEAN® surface also reduces radiated heat loss to less than 10% of a conventional steel plate griddle. By keeping heat on the surface and out of the kitchen, the MIRACLEAN® Griddle reduces air conditioning demands and gives the chef a cooler cooking environment.

**Reduces flavor transfer**

The smooth MIRACLEAN® surface prevents food particles from being trapped as they are in steel plate griddles. The surface virtually eliminates flavor transfer.

**Saves 44% in clean up**

A documented study by the University of Illinois General Engineering department confirmed what has long been known by MIRACLEAN® operators - cleaning the MIRACLEAN saves time! 44% savings means less labor cost and high productivity. Cleaning a 36" MIRACLEAN versus a conventional steel plate model 3x daily would mean savings of \$2,600 over the life of the unit. Cleaning the surface takes 3 easy steps:

1. scrape with the Keating scraper
2. wash with a Keating palmetto brush and water
3. polish with Keating Klenzer and a damp cloth

No more griddle bricks, grill screens or harsh chemicals needed, and reseasoning the plate is not necessary.

**Accurate temperature control**

MIRACLEAN® Griddles feature zoned temperature control to ensure temperature accuracy in cooking. The MIRACLEAN surface allows the operator to cook at lower temperatures to control the degree of caramelization and product shrinkage.



As continuous product improvement occurs, specifications may be changed without notice.

DATE \_\_\_\_\_

APPROVAL \_\_\_\_\_

SIGNATURE \_\_\_\_\_

[www.keatingofchicago.com](http://www.keatingofchicago.com)

24" MIRACLEAN® Gas Griddle

"Serving Those Who Serve The Very Best"®

**KEATING**  
OF CHICAGO, INC.

## 24" MIRACLEAN® Gas Griddle

A minimum of 24" at the front of the unit should be allowed for servicing and operation; a minimum of 6" on each side and at the rear of each unit for combustible materials.

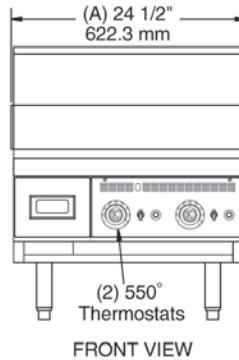
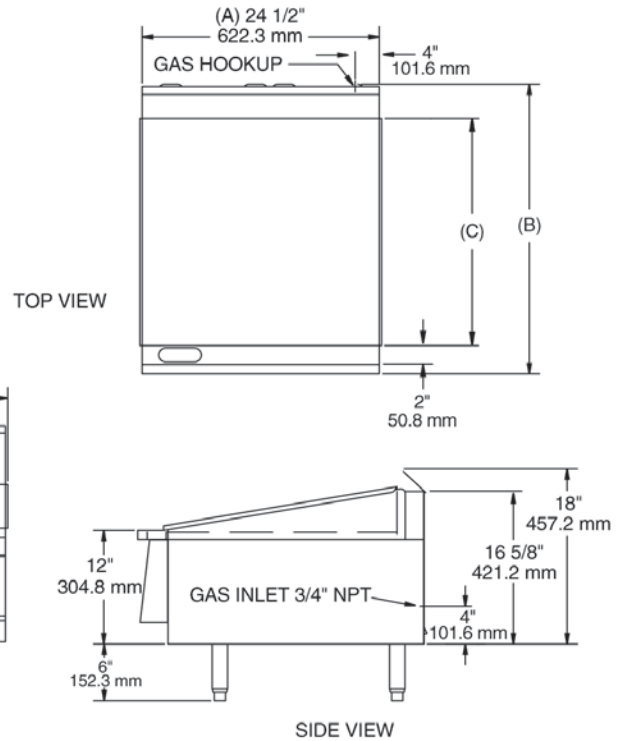

### SPECIFICATIONS

**Griddle Plate** - High carbon, 3/4" steel plate with our patented Trivalent Chromium surface applied in a special 8-step process to ensure a mirror smooth surface. The MIRACLEAN® plate has an emissivity rating of .078.

**Drain Trough** - A 2" trough is across the front, with a 4" x 1 1/2" drain in the left front. It is located above a large stainless steel grease drawer with baffles and a rear handle. The perimeter and grease trough are 14 gauge stainless steel. The perimeter is 4 1/2" high across the back with sides angling from 4 1/2" in the rear to 1/2" at the front. Sides and rear perimeter have an exterior trim of 22 gauge stainless steel.

**Gas Burners** - Atmospheric type "H" shaped cast iron construction, with one burner for every 12" of linear plate surface. Each pilot is manually ignited with a (piezo) igniter.

**Cabinet** - The cabinet has an inner liner made of 20 gauge aluminized steel. The outer cabinet has 14 gauge stainless steel sides, an 18 gauge stainless steel back and 16 gauge aluminized steel bottom. A stainless steel flue diverter has been added to extend flue.

**Thermostat** - Millivolt sealed contacts, close range, hydraulic type, accurate to  $\pm 5^\circ$  from 250° to 550°F. Application of this thermostat is patented by Keating.

**100% Safety Shut Off** - Millivolt, thermocouple type with 100% safety shut off.

**Standard Accessories** - Keating razor scraper with a packet of 10 blades, 4" wide spatula, long handle palmetto brush, egg turner and sample of Keating Klenzer.

**Electrical Connections** - Not required.

**Gas Requirements** - Install a 3/4" male NPT connection and 4" water column pressure (natural gas). Supply pressure must be 7" (natural gas) and 11" (LP) water column.

**Special Order Options** - 4" legs, stand, stand with shelf and casters, cutting board (stainless or richlite), plate shelf, thermostat knob guard, belly bar, streaked surface, custom griddle styles and configurations, and security package.

**INSTALLER** - Check plumbing and gas codes for proper gas supply line sizing to sustain burner pressure when all gas appliances are full on. Supply pressure must NOT be above 13.84" WC or gas valve damage may occur.

### GAS REQUIREMENTS / DIMENSIONS

MODEL	BTU/hr. NG	BTU/hr. LP	Burners	T-Stats	(A) Width	(B) Depth	Height	Working Height	(C) Plate Size	Weight
24x30 FT	60,000	60,000	2	2	24 1/2"	30 5/8"	18"	12"	24" W x 24" D	265 lbs.
24x36 FT	73,000	73,000	2	2	24 1/2"	36 5/8"	18"	12"	24" W x 30" D	275 lbs.

FT = Front Trough Only

### NOT FOR OUTDOOR INSTALLATION - NOT FOR DOMESTIC INSTALLATION

As continuous product improvement occurs, specifications may be changed without notice.

[www.keatingofchicago.com](http://www.keatingofchicago.com)

24" MIRACLEAN® Gas Griddle